



M
30

30 kgs.
65 lbs.



*Compact size.
Produces up to 30*
kgs./65 lbs. of ice
every 24 hours with
a storage capacity
of 14 kgs./30 lbs.
Ideal for any small-
volume ice need.*

*Production rating outside the scope
of ARI Standard 820.

- ◆ *Attractive Stainless Steel Cabinet
– Euro-Design*
- ◆ *Easy Access Door, Slides
Up & Out of the Way*
- ◆ *Patented Cleaning &
Sanitizing Technology*
- ◆ *Easy Access Air Filter*
- ◆ *Front Air Intake & Exhaust*
- ◆ *CFC-FREE R-134A Refrigerant*
- ◆ *Manitowoc Proven Vertical
Evaporator*
- ◆ *Computerized Control*
- ◆ *Patent-Pending Worldwide*
- ◆ *3 Year Parts & Labor Warranty*

Manitowoc®
ICE MACHINES

QM30

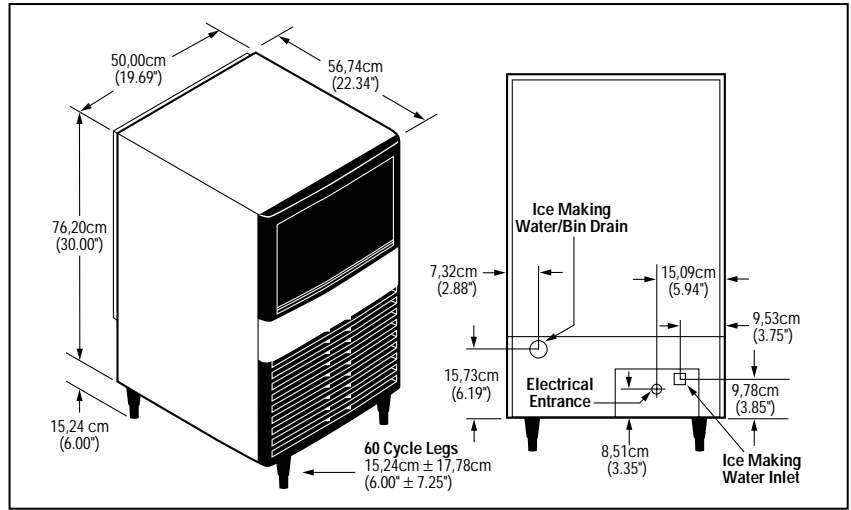

Model	Cube size	Ice production 24 hours	Power kWh/100 lbs.	Storage Bin Capacity
QM30A	dice	52 lbs. 24 kgs.	20.4	30 lbs. 14 kgs.
Water usage/100 lbs./45.4 kgs. of Ice • Potable Water: 38.4 gallons, 146 liters				

A following model number indicates "Air" cooled condensing unit.

 Certified In Accordance With ARI Ice Storage Bins Certification Program, which is based on ARI Standard 820

air temp	24-HOUR PRODUCTION † lbs./kgs.		
	50°	70°	90°
F	50°	70°	90°
C	10°	21°	32°
70°	65	60	
21°	30	28	
80°	60	56	50
27°	28	25	23
90°	55	52	47
32°	25	24	21
100°		45	43
38°		21	20

CUBE SIZE Dice: 19mm x 19mm x 19mm (7/8" x 7/8" x 7/8"). 

ELECTRICAL 115/60/1 ice machines are factory pre-wired with a 180 cm (6') power cord and NEMA 5-15P-plug configuration. (230/50/1 also available, see 50 cycle literature.)

Total Amps: 5.3 amps.

Maximum fuse size: 15 amps.

HACR-type circuit breakers can be used in place of fuses.

COMPRESSOR 1/4 HP.

CONDENSER Air-cooled.

OPERATING ENVIRONMENT Ambient temperature 10-45°C (50°-113°F).

Potable water temperature 10-40°C (50°-104°F).

Water pressure 240-620 kPa (34-90 psi).

INSTALLATION CLEARANCE None required top and sides but allow space for water supply, drain, and electrical connection in back.

AIR FILTER



Quickly removed, slides out from left side front without tools, easy to clean, reusable filter protects condenser from lint, grease and dust.

CLEANING SYSTEM Built-in cleaning and sanitizing technology. 

LEGS Adjustable from 15.24 to 17.78 cm. (6.00"-7.25").

ICE STORAGE One piece bin liner (seamless) "Rotocast" polyethylene.

INSULATION Foamed-in-place with CFC-FREE foam.

LISTINGS



Manitowoc® ICE MACHINES

Manitowoc Ice, Inc. ♦ Phone: 920-682-0161 ♦ Fax: 920-683-7589 ♦ www.manitowocice.com

Form 9352C Fax Litho in USA 11-99 ©1999 MANITOWOC

Continuing product improvement may necessitate change of specifications without notice.